

PVV104 Series Pressure and Vacuum Vent

The PVV104 series pressure and vacuum relief vents are used on tanker trucks and incorporates roll-over protection. It prevents the build up of pressure and vacuum caused by expansion, contraction and tanker movement.

The PVV104 is designed primarily for thermal relief. The vent incorporates roll-over protection such that it locks shut at any angle greater than 60° from the vertical. The vent is normally mounted directly to the manhole on the underside of the emergency vent.

Key Features

- The PVV range of vents are mounted inside the tank either on the manhole or on a separate flange.
- There are various designs, but all allow excess pressure and vacuum to be equalised through a gauzed flame proof opening.
- All have roll-over protection ensuring compartment is sealed if tilted more than 60° from vertical.

Ordering Information

- **PVV104:** Pressure and vacuum vent suitable for Australia/NZ.
- **PVV104U:** Pressure and vacuum vent suitable for International markets.
- **PVV104M:** Pressure and vacuum vent suitable for Australia/NZ (metric).
- **PVV104UM:** Pressure and vacuum vent suitable for International markets (metric).

Specifications

DISMANTLE	Remove circlip from bottom to allow pressure & vacuum poppet to be removed. Wind out rollover spring to remove rollover poppet.		
MOUNTING	Specify where the vent is to be mounted & Liquip will supply the complete kit i.e.: <ul style="list-style-type: none"> • On VOH400 series hatch • On VOH200 & VOH700 series hatches • On SH300 series swing back hatches • On remote weld flange • A cylindrical gauze (spark arrestor) is mounted into the dome shaped indentation of the manlid to prevent flashbacks. 		
MATERIALS AND WEIGHT	<ul style="list-style-type: none"> • Aluminium body & poppets • Stainless steel springs • Bonded nitrile seals • Nylon coated bronze ball • Weight: 0.6kg 		
TECHNICAL DATA	<table border="0"> <tr> <td style="vertical-align: top;"> PVV104/PVV104M (Australia/NZ) <ul style="list-style-type: none"> • Pressure: 10 to 17 kPa • Vacuum: 0 to -4 kPa • Capacity: 98m³/hr free air at 35kPa • Locks shut at 60° from vertical • Approved to AS2809 • PVV104 is identified by the free air bleed hole in the body. </td> <td style="vertical-align: top;"> PVV104U/PVV104UM (International) <ul style="list-style-type: none"> • Pressure: 8 to 12kPa • Vacuum: -0.4 to -2.5kPa • Capacity: 90m³/hr free air at 30kPa inlet & 33m³/hr free air at 3kPa pressure drop for vacuum. • Locks shut at 60° from vertical • Approved to International requirements. • PVV104U has no bleed hole and a very distinctive full circle marker groove around the body. </td> </tr> </table>	PVV104/PVV104M (Australia/NZ) <ul style="list-style-type: none"> • Pressure: 10 to 17 kPa • Vacuum: 0 to -4 kPa • Capacity: 98m³/hr free air at 35kPa • Locks shut at 60° from vertical • Approved to AS2809 • PVV104 is identified by the free air bleed hole in the body. 	PVV104U/PVV104UM (International) <ul style="list-style-type: none"> • Pressure: 8 to 12kPa • Vacuum: -0.4 to -2.5kPa • Capacity: 90m³/hr free air at 30kPa inlet & 33m³/hr free air at 3kPa pressure drop for vacuum. • Locks shut at 60° from vertical • Approved to International requirements. • PVV104U has no bleed hole and a very distinctive full circle marker groove around the body.
PVV104/PVV104M (Australia/NZ) <ul style="list-style-type: none"> • Pressure: 10 to 17 kPa • Vacuum: 0 to -4 kPa • Capacity: 98m³/hr free air at 35kPa • Locks shut at 60° from vertical • Approved to AS2809 • PVV104 is identified by the free air bleed hole in the body. 	PVV104U/PVV104UM (International) <ul style="list-style-type: none"> • Pressure: 8 to 12kPa • Vacuum: -0.4 to -2.5kPa • Capacity: 90m³/hr free air at 30kPa inlet & 33m³/hr free air at 3kPa pressure drop for vacuum. • Locks shut at 60° from vertical • Approved to International requirements. • PVV104U has no bleed hole and a very distinctive full circle marker groove around the body. 		
ASSOCIATED EQUIPMENT	<ul style="list-style-type: none"> • VOH400 series hatch • VOH200 & VOH700 series hatches • SH300 series swing back hatches 		

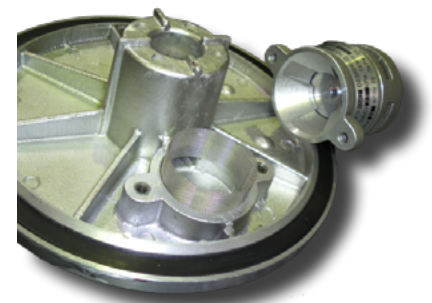

PVV adjacent to manlid (PVV ball not shown)

PVV104, PVV104M, PVV104U & PVV104UM

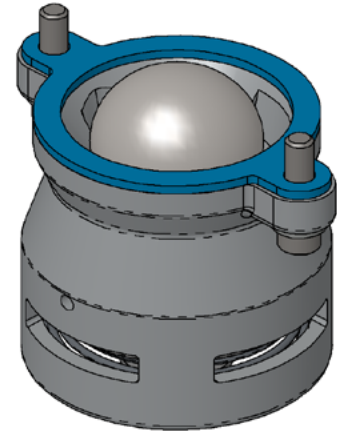
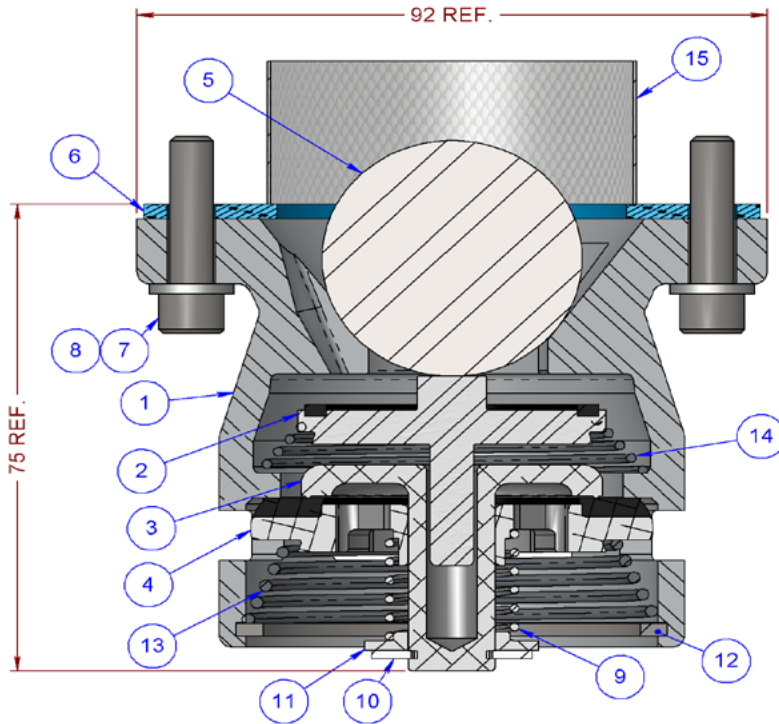

SEE DATASHEET X952196
FOR MOUNTING OPTIONS

ITEM NO.	PART NUMBER	DESCRIPTION	PVV104	PVV104M	PVV104U	PVV104UM	MATERIAL
1	PVV104-1	BODY - WITH HOLE	1	1	-	-	ALUMINIUM
	PVV104-1U	BODY - WITH GROOVE	-	-	1	1	ALUMINIUM
2	PVV104-7	ROLLOVER POPPET	1	1	1	1	ALUMINIUM
3	PVV104-8	PRESSURE POPPET	1	1	1	1	ALUMINIUM
4	PVV104-9	VACUUM POPPET	1	1	1	1	ALUMINIUM
5	PVV104-13	BALL Ø38	1	1	1	1	NYLON/BRONZE
6	4250	GASKET	1	1	1	1	NBR-CORK
	0714	CAPSCREW IMPERIAL	2	-	2	-	Z/P STEEL
7	55024	CAPSCREW METRIC	-	2	-	2	ST STEEL
	0107	WASHER SPRING	2	-	2	-	Z/P STEEL
8	5269	WASHER SPRING	-	2	-	2	Z/P STEEL
	4420	SPRING	1	1	-	-	ST STEEL
9	6109	SPRING	-	-	1	1	ST STEEL
	0096	E-CLIP IMPERIAL	1	1	1	1	Z/P STEEL
11	PVV104-3	SPRING RETAINER	1	1	1	1	ALUMINIUM
12	4347	CIRCLIP INTERNAL	1	1	1	1	Z/P STEEL
13	4419	SPRING COMPRESSION	1	1	1	1	ST STEEL
14	4421	SPRING COMPRESSION	1	1	1	1	ST STEEL
15	VOH700-19	SPARK ARRESTOR	1	1	1	1	ST STEEL
16	6436	INSTRUCTION LEAFLET	1	1	1	1	PAPER
17	59052	LABEL	-	-	1	1	ALUMINIUM
18	55031	RIVET	-	-	1	1	STEEL
19	59051	TEST CERTIFICATE	-	-	1	1	PAPER

METERS - VALVES - VENTS - MANHOLES - HOSEREELS - OVERFILL PROTECTION - LOADING ARMS - ELECTRONIC DIPSTICKS



LIQUIP INTERNATIONAL PTY LTD
148B NEWTON RD, WETHERILL PARK, SYDNEY N.S.W. AUSTRALIA 2164
Phone: +61 2 9725-9000 Web: www.liquip.com

X952096

Sheet 1 of 1
Issue: K

VOH451 MANHOLE ASSEMBLY

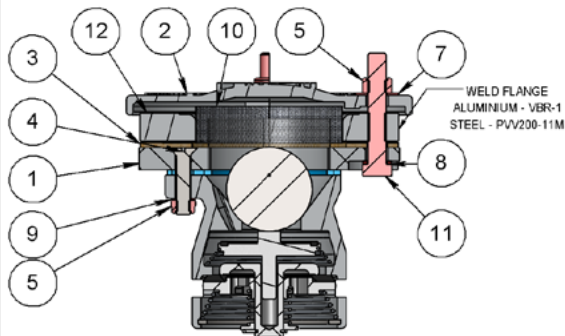

REQUIRED TO MOUNT TO WELD FLANGE

ITEM NO.	PART NUMBER	Desc1	MATERIAL	QTY.
1	PVV104-10	FLANGE ADAPTOR FOR	ALUMINIUM	1
2	PVV104-11	WEATHER COVER FOR PVV104	ALUMINIUM	1
3	0658	GASKET	NBR-CORK	1
4	55055	SCREW C/SUNK MET	ST STEEL	2
5	6549	NUT HALF GLENLOC	ST STEEL	5
7	6605	WASHER FLAT	ST STEEL	3
8	5390	WASHER FIBRE	FIBRE	3
9	4358	WASHER FIBRE MET	FIBRE	2
10	PVV104-12	SPARK ARRESTOR GAUZE FOR PVV104	ST STEEL	1
11	55063	SETSCREW METRIC	ST STEEL	3
12	VRB-1	FLANGE WELD	ALUMINIUM	1

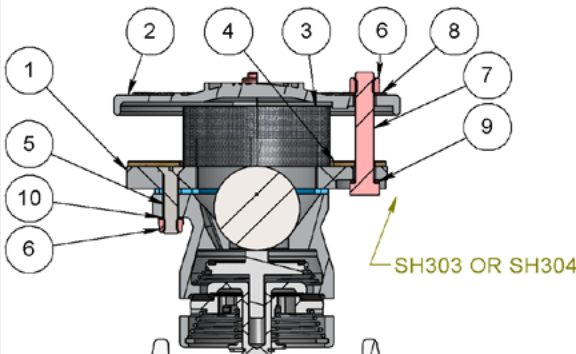

REQUIRED TO MOUNT TO SH303 & SH304

ITEM NO.	PART NUMBER	Desc1	MATERIAL	QTY.
1	PVV104-10	FLANGE ADAPTOR FOR	ALUMINIUM	1
2	PVV104-11	WEATHER COVER FOR PVV104	ALUMINIUM	1
3	PVV104-6	SPARK ARRESTOR GAUZE FOR PVV104	ST STEEL	1
4	0658	GASKET	NBR-CORK	1
5	55055	SCREW C/SUNK MET	ST STEEL	2
6	6549	NUT HALF GLENLOC	ST STEEL	5
7	55063	SETSCREW METRIC	ST STEEL	3
8	6605	WASHER FLAT	ST STEEL	3
9	5390	WASHER FIBRE	FIBRE	3
10	4358	WASHER FIBRE MET	FIBRE	2

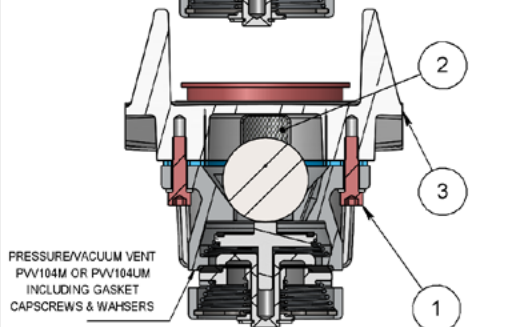

REQUIRED TO MOUNT TO VOH700-4U-METRIC

ITEM NO.	PART NUMBER	Desc1	MATERIAL	QTY.
1	PVV104M	PRESSURE AND VACUUM VENT	ALUMINIUM	1
2	VOH700-19	SPARK ARRESTOR	ST STEEL	1
3	VOH700-4U-METRIC	EMERGENCY VENT COVER 9"	ALUMINIUM	1

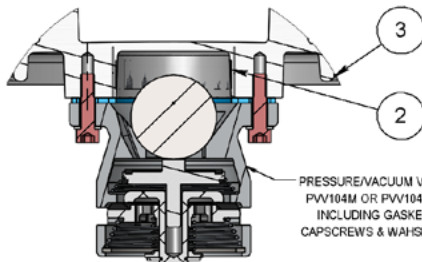

REQUIRED TO MOUNT TO VOH400-4U-METRIC

ITEM NO.	PART NUMBER	Desc1	MATERIAL	QTY.
1	PVV104M	PRESSURE AND VACUUM VENT	ALUMINIUM	1
2	PVV104-4	SPARK ARRESTOR GAUZE	ST STEEL	1
3	VOH400-4U-METRIC	EMERGENCY VENT COVER 9"	ALUMINIUM	1

FOR BOLT ON DIRECT TO WALKWAY, WELD ON TO ALUMINIUM WALKWAY OR WELD ON TO STEEL WALKWAY, REFER TO X952196

MAXIMUM TEMPERATURE FOR BONDED SEALS

- WHEN STEAM CLEANING TANKS, CARE MUST BE TAKEN NOT TO DAMAGE SEAL COMPONENTS SUCH AS THE SEALS IN THE PVV104M VENTS.
- THE SEAL IN THE PVV104 SERIES ARE A BONDED NITRILE AND THE MAXIMUM STEAM CLEANING TEMPERATURE THAT CAN BE USED WITHOUT DAMAGING THE SEAL AND BONDING IS $110 \pm ^\circ\text{C}$.
- DO NOT OVER HEAT THE PRESSURE VACUUM VENTS WHEN STEAM CLEANING TANKS AS THIS WILL CAUSE PERMANENT DAMAGE TO THE BONDED SEALS.

METERS - VALVES - VENTS - MANHOLES - HOSEREELS - OVERFILL PROTECTION - LOADING ARMS - ELECTRONIC DIPSTICKS

LIQUIP
PART OF OPW a DOWDER company

LIQUIP INTERNATIONAL PTY LTD

148B NEWTON RD, WETHERILL PARK, SYDNEY N.S.W. AUSTRALIA 2164

Phone: +61 2 9725-9000 Web: www.liquip.com

X1250020

Sheet 1 of 1
Issue: A

X1250020 A

Mounting Instructions

Liquip's PVV104 series vents are supplied separately to VOH series manholes to allow for easier hydro testing by the customer. After testing they need to be mounted by following the instructions below.

1. Open the emergency vent lid by lifting the handle then the bridge to provide access to underside of lid.
2. Remove PVV assembly (and all loose parts) from bag and insert cylindrical gauze into dome shaped indentation as shown.
3. Insert ball into PVV vent and put gasket on the sealing face and mate it to the sealing face on the underside of the lid.
4. Insert capscrew through spring washer and then through casting and screw assembly onto lid – repeat for other side.
5. Tighten capscrews to a torque of 7.2Nm (5.6ft lbs)
6. Open and close lid a couple of times to make sure ball is free to move.

