

# FITTING CLAMPBANDS

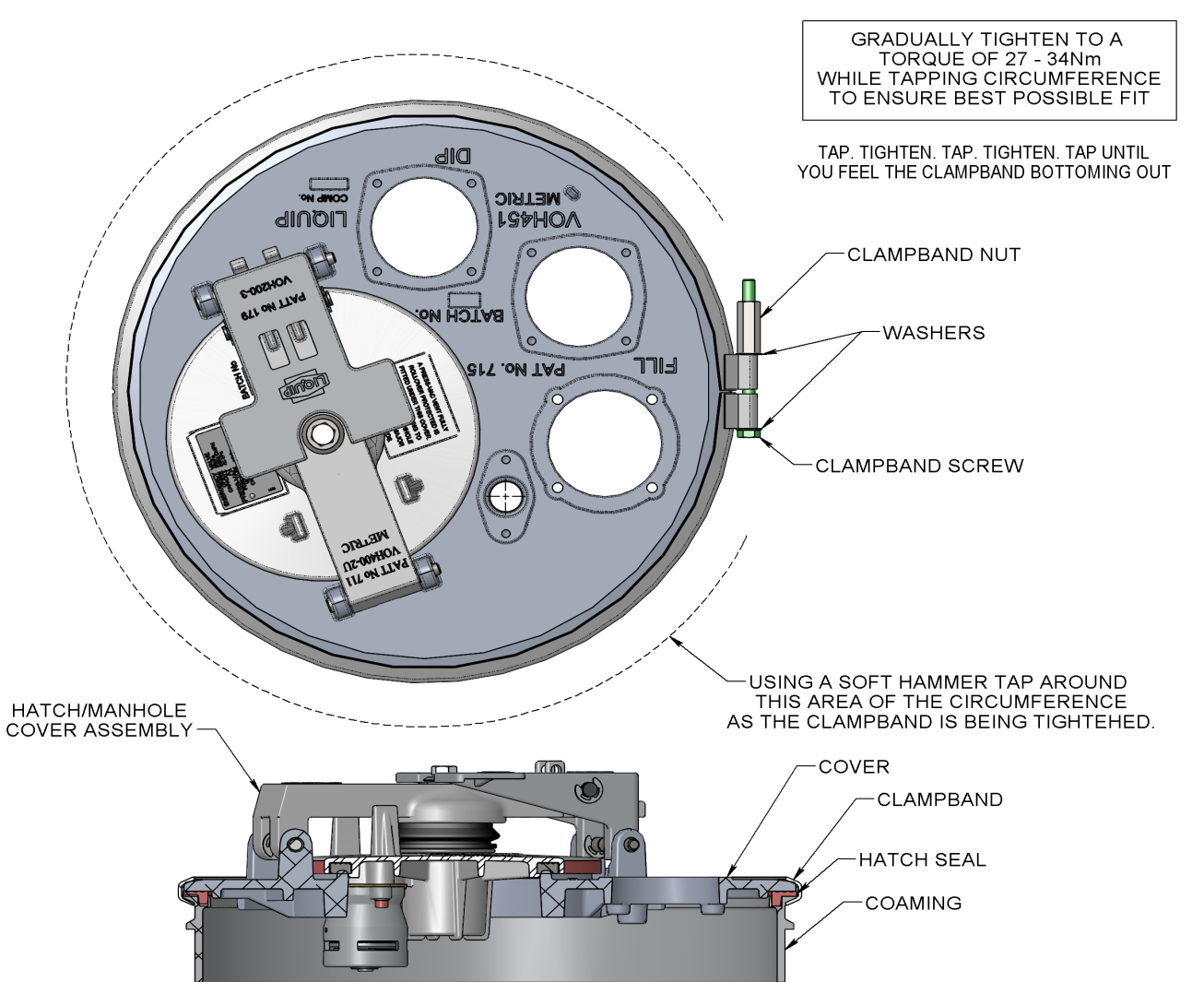

## FITTING CLAMPBANDS

- ENSURE SEAL SITS CORRECTLY BETWEEN COAMING & HATCH (SOME MODELS MAY DIFFER FROM SHOWN).
- OPEN CLAMPBAND AND FIT OVER CIRCUMFERENCE OF COVER & COAMING. THEN FIT SCREW, NUT & WAHSERS.
- HATCH & COAMING WITH A NOTCH ON THE DIAMETER USE A CLAMPBAND WITH AN INDENT TO SUIT.
- TAP AROUND THE OUTSIDE OF THE CLAMPBAND WITH A SOFT HAMMER TO ENSURE PROPER FITTING.
- AS THE CLAMPBAND IS TIGHTENED, THE SEAL IS COMPRESSED BETWEEN THE COVER & COAMING.
- GRADUALLY TIGHTEN CLAMPBAND SREW/NUT TO A TORQUE OF 27 - 34Nm WHILE CONTINUEIENG TO TAP AROUND THE CIRCUMFERENCE OF THE BAND.

METERS - VALVES - VENTS - MANHOLES - HOSEREELS - OVERFILL PROTECTION - LOADING ARMS - ELECTRONIC DIPSTICKS



**LIQUIP INTERNATIONAL PTY LTD**  
148 Newton Road Wetherill Park, Sydney, NSW, AUSTRALIA, 2164  
Phone: (+61) 2 9725 9000  
www.liquip.com

**X1250220**

Sheet 1 of 1  
Issue: A