

# HOW IT WORKS - VOH450

## Operation

The VOH450 Series includes as standard an emergency vent, which also must comply to the AS 2809-2: Standard.

The manhole's primary use is as access to the compartment for repairs and maintenance for your convenience.

When the manhole was designed we also incorporated the Emergency Vent, Inspection Hatch, PVV Vent, Overfill Probe, Dip Point, Fill Point and Vapour Mount. These components can however be mounted separately from the manhole.

Every VOH450 is fitted with a rollover protected pressure vacuum vent (for details on it's operation refer to "How it Works" PVV104/PVV104M)



*Manholes must comply with Australian Standards AS 2809-2 in relation to the drop test described in Appendix B of that standard.*

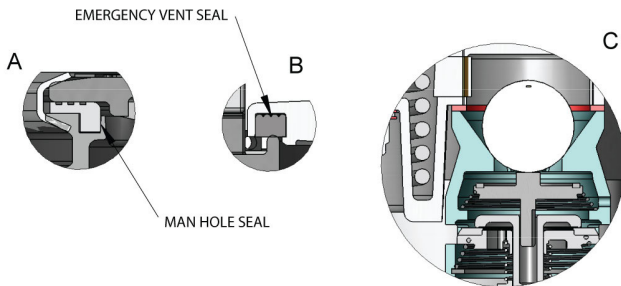
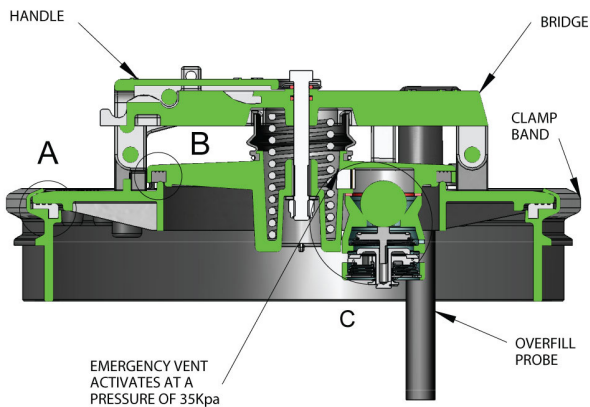

### Know Your Drop Tests

AS2809 up until the AS2809:2020 revision required manhole covers to be dropped on a certified drop test apparatus, which simulates a full compartment of product, from a height of 1.2 metres & then a secondary drop from 1 metre.

This double drop replicates a tanker's initial impact and often subsequent secondary impact i.e. rollover. An Australian double drop test approved manhole cover provides the highest level of product containment within the compartment when it's needed most.



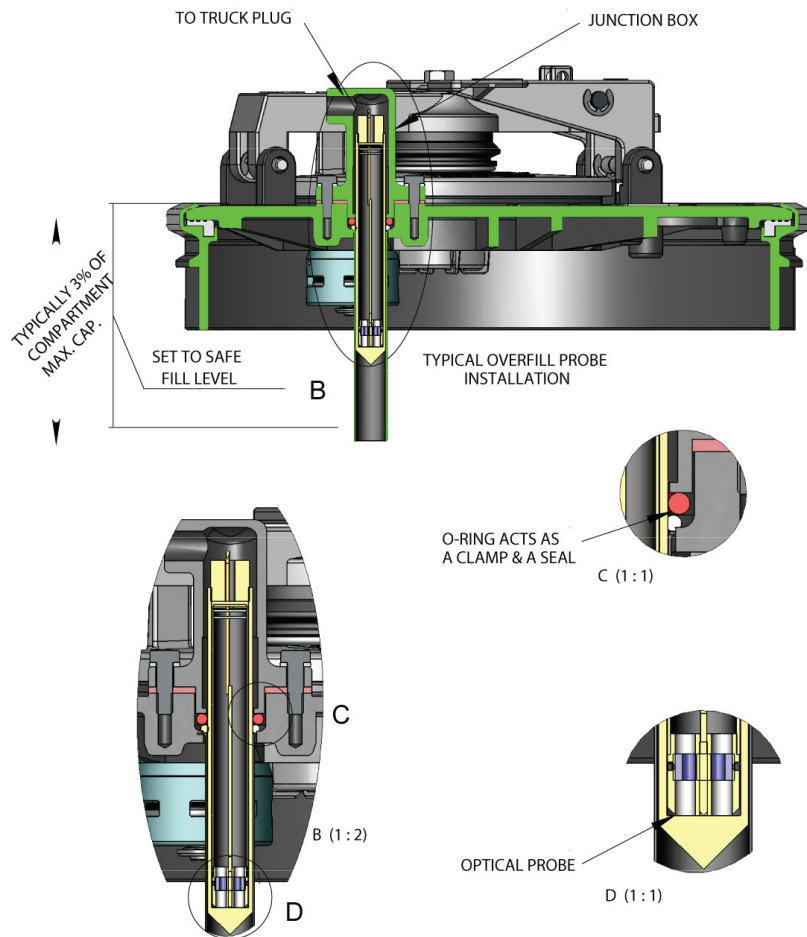

### Inspection Hatch Operation

Hatch is closed and emergency vent is activated.

To open inspection hatch lift handle.

The safety catch will prevent damage or injury if the compartment is pressurised.

Lift bridge to access or view compartment contents and repair or inspect pressure vacuum vent. Emergency vent and PVV are deactivated when open.

