

Document:	EBW Tech Talk
Date:	28/9/95
Author:	MM

## EBW PRODUCT TECH. TALK

TO16

### INTRODUCTION

*Comments written on original.*

EBW INC. is a supplier of petroleum handling equipment based in Muskegan, Illinois USA. It has a distributor network of over 500 firms throughout the world, most being located in northern America. EBW also owns an Electronics Company called EBW Electronics, as well as Advanced Polymer Technologies or APT.

Up until 15 years ago approximately 50% of EBW's product range was made up of castings for the automotive industry. A change of ownership in 1979 has meant a change in direction, with 98% of the entire product range being devoted solely to petroleum handling equipment. Now 75% of EBW's total annual sales are attributed to service station equipment, with most of the remaining 25% made up by tank truck equipment.

### EBW PRODUCT RANGE

#### A) Service Station Equipment

- Tank Monitoring Systems
- ✓ • Spill Containment Manholes
- Automatic Overfill Protection Valves
- Vapour Recovery Equipment (1<sup>st</sup> and 2<sup>nd</sup> Stage)
- ✓ • Emergency Shut off Valves, *SHEAR VALVES,*
- Safety Sever Hose Breakaway Couplings
- Extractor Vent Valves
- Test Well Monitors
- ✓ • Fiberglass Manhole Covers
- Drop Tubes
- ✓ • Caps and Adapters
- Nozzles
- ✓ • APT Piping and Accessories

#### B) Tank Truck Equipment

- Bottom Loading Valves
- Tight Fill Elbows
- Vapour Recovery Valves
- Air Interlock Valves
- Hose Couplings
- Probes and Control Boxes (Starship)
- Bulk Delivery Nozzles

### ***LIQUIP'S INVOLVEMENT WITH EBW***

Liquip has been involved with EBW for around 10 years. Initially Liquip used EBW overfill probes (the "Starship" range), truck plugs, dummy probes and shear valves.

More recently Liquip has developed it's own overfill protection items, thereby eliminating the need to use the Starship products. Most interest now lies in the APT range of piping and accessories and other service station equipment including shear valves, 42" manholes, spill containment manholes, emergency shut off valves, free air vents and fill adapter caps.

### ***TECH TALK OUTLINE***

This technical bulletin will specifically look at items relevant to Liquip Sales presently.

Products covered in this report will only include the service station equipment namely tank monitoring systems, spill containment manholes, 42" fiberglass manholes, automatic overfill prevention valves, emergency shutoff valves, free air vents and tank adapter caps.

## **TANK MONITORING SYSTEMS**

EBW primarily offers 2 tank monitoring systems which are the Auto Stik II and the Auto Stik JR.

Briefly these systems are designed to monitor storage tanks and produce the following reports:

- Tank charts.
- Current inventory (using Auto Stik “in-tank” probes) including a shift report showing a net change in gallons and shift times.
- Leak detection by an automatic pass/fail analysis.
- Delivery times.
- Tank Setup.
- Contact report.
- Alarm report.

Both systems are IBM PC compatible and with the appropriate software can be remotely programmed and monitored by way of modem.

The Auto Stik II’s primary features include:

- 8 tank probes expandable to 16.
- 16 sensor inputs expandable to 64.
- 8 relays expandable to 56.
- LCD display with 4 lines and 40 characters per line.
- 32 column printer with external printer option.
- Audible alarm system.

The Auto Stik JR is basically a smaller unit developed for smaller applications with only up to 4 tanks. It’s features include:

- 4 tank probes.
- 8 sensor inputs.
- LCD display with 4 lines and 40 characters per line.
- 32 column printer.

Both units have a simple 15 function key pad and pull down menu system. Relay expansion modules, remote display panels and heater boxes are also available.

They are UL listed and third party tested but not SAA approved for use in hazardous areas in Australia. Other companies that market tank monitoring systems in Australia include Red Jacket, Veeder Root, Enraf, SAAB and Compac. These are all SAA approved.

EBW also offers the Sensor Monitor, which is a leak detection system capable of monitoring up to 16 sensor inputs. It has an internal alarm with an external alarm option and can monitor double walled tanks, piping sumps, dispenser sumps and ground water wells.

The range of sensing probes includes liquid level sensors for sumps and double wall tanks, well monitor sensors, float sensors for hydrostatic reservoirs of double wall tanks and discriminating sensors that can detect and differentiate between water and hydrocarbons using a polymer strip.

### FREE AIR TANK VENTS

These vents are a simple unit designed to discharge vapour upwards into the air. The top dome casting and furrows around the rim serve to drain of water etc. They meet US NFPA Code 30 requirements.

The EBW range comes in 1 ½", 2" and 3". They simply slip on to the vent piping and are secured by a plated screw.

Construction is cast aluminium, with a bronze flame arresting gauze.

Size	Part Number
1 ½"	800-206-01
2"	800-207-02
3"	800-203-01



### 42" SAFE-LITE FRC BOLT DOWN MANHOLE COVER

The Safe-Lite 42" manhole covers for tank sumps are made from Fiber Reinforced Composite or FRC. The primary benefit is a huge reduction in the weight of the cover compared to the traditional steel covers widely used today. The FRC covers range from 20.4 kgs to 43 kgs while steel covers of the same sizes range from 68 kgs to 100 kgs.

The FRC cover has been tested to over 23,000 kgs load without failure which is 2 ½ times the US D.O.T H20 load rating requirement. They have also successfully withstood 30 year life cycle tests, with 11,000 loading cycles of 9,000 kgs each.

The covers are also available in 30" and 36", as well as a wide variety of colours including black, white, red, green, blue, yellow, orange and grey. Models with spring loaded handles are also available.

They are used in conjunction with the Liquip manufactured 42" steel skirt, to which they are secured with 5 stainless steel bolts. The skirt is made of 14 gauge mild steel, while the coaming ring is made of 40 x 40 x 6mm mild steel angle.

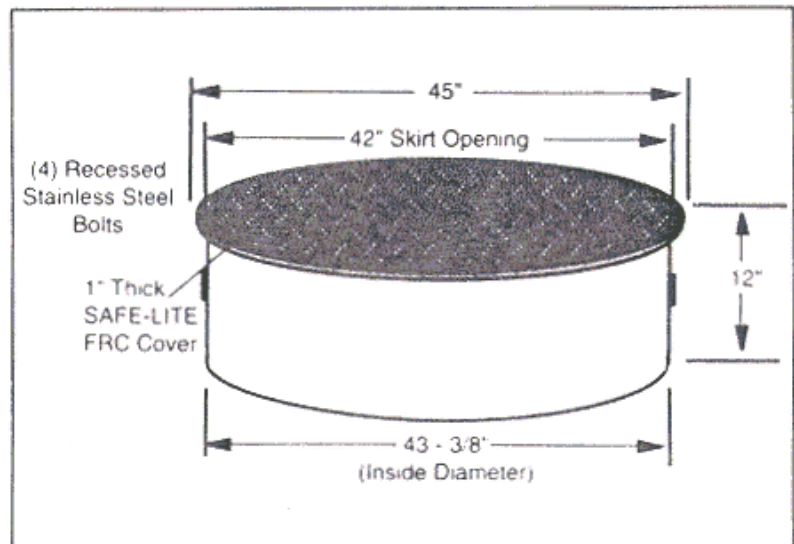



## GRADE LEVEL SPILL CONTAINMENT MANHOLE

These are designed to catch spills that occur during fuel delivery at the fill points. At most a service stations the fill points are located close together so a spill tray or multiple adaptor spill box is used. The EBW range however are designed for use only with individual fill points. The spilt product is captured in the reservoir, then released via a manually operated drain back into the riser pipe for return to the tank.

They are simply installed in the following manner. The threaded base (which is basically a 4" BSP socket) is attached to the tank riser, then an additional length of pipe complete with tank fill adaptor is threaded to the inside of the container.

Their construction comprises of a Fibre Reinforced Composite (FRC) cover (also available in aluminium or cast iron), a flexible polyethylene shell and a cast iron base (also available in composite).

Variations include a "snap on" type cover, a retrofit version that slips over the existing riser pipe and is secured into place with a flange and a below grade level version that is positioned beneath an 18" manhole and skirt.

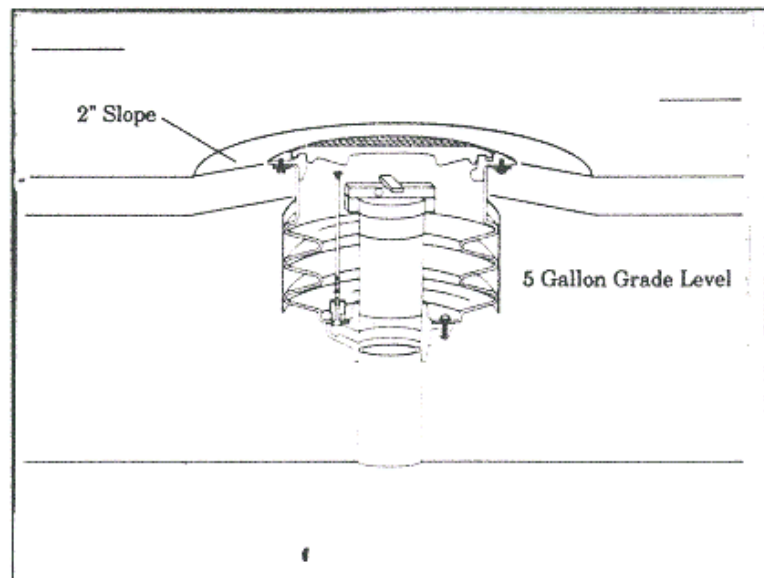

## AUTO LIMITER II AUTOMATIC SHUT OFF VALVE

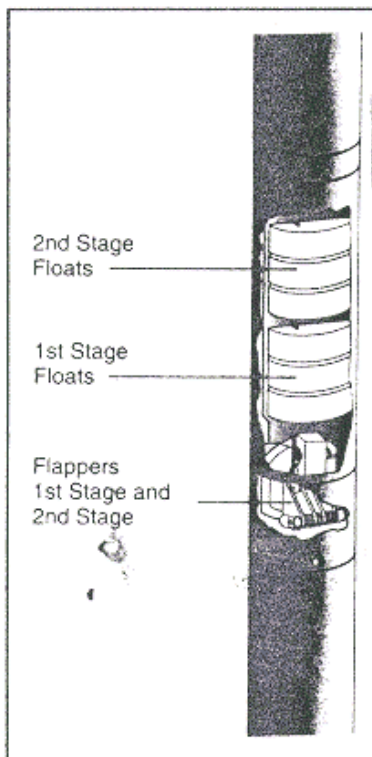

The Auto Limiter II is an overfill protection system that is installed inside the 4" riser pipe of underground storage tanks. It is primarily a shut off valve activated by floats in two stages.

The two stage shut down reduces the flow rate by 90% at the first stage, being about 92% of tank capacity, then stops flow at the second stage at 95% ( this can be set at up to 99%) of tank capacity. The reduction in flow rate at the first stage serves to reduce line shock at the second stage shut off.

After complete shut off and the trucks outlet valves have been closed, the Auto Limiter II allows hose to drain by allowing the flappers to lift slightly. Manual dipping is also possible after shut off.

The body is constructed of anodized aluminium, polyethylene floats, zinc first stage flapper and acetal second stage flapper.

In Australia the most popular model is the Emco Wheaton Guardian, which features "self cleaning" Teflon floats and a high drain rate bleed valve.

## SIDE SEAL FILL CAP

The EBW side seal tight fill adaptor cap is designed especially for side seal fill point adaptors. It provides a seal both water and vapour tight. It's "T" handle design makes for simple removal and replacement. It is also lockable.

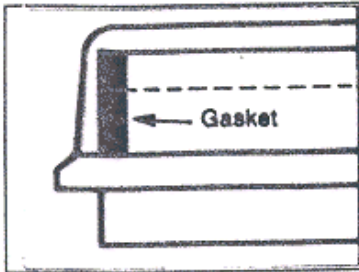

It has an epoxy coated aluminium body, stainless steel latches and iron - copper infiltrated cams.

## EMERGENCY SHUT OFF VALVE

More commonly known as "shear valves" these are available in single and double poppet versions. Their function is to stop product flow in the event of a fire or a collision at the product dispenser. ~~They are only used in pressure systems.~~

If a collision occurs the top adaptor will shear clean forcing the poppet on the lower section to swing shut preventing fuel spillage. The double poppet version also has a poppet in the top adaptor which closes upon shearing and prevents leakage from the product dispenser.

In a fire the fusible link will release the fulcrum arm, allowing the poppet to seal.

The inlet and outlet are a standard 1.5" in NPT male or female thread, union or compression fittings. They can be boss or u-bolt mounted. Replacement adapter kits are also available.

They are both UL listed and comply NFPA 30A requirements.

### Double Poppet

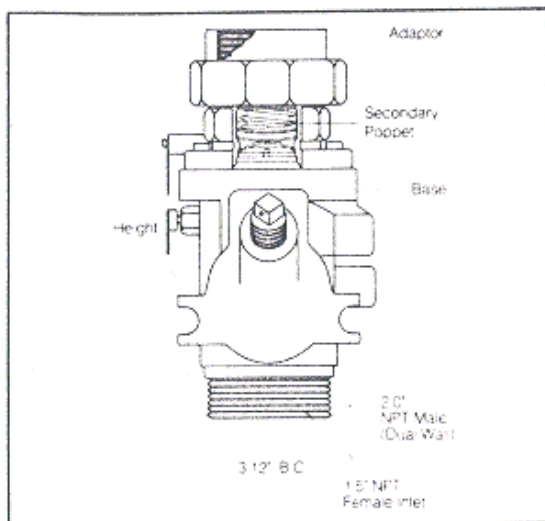

### Single Poppet

